

PROTECT.

RANGER E “Eagle”

Horizontal log splitter

PERFORM.

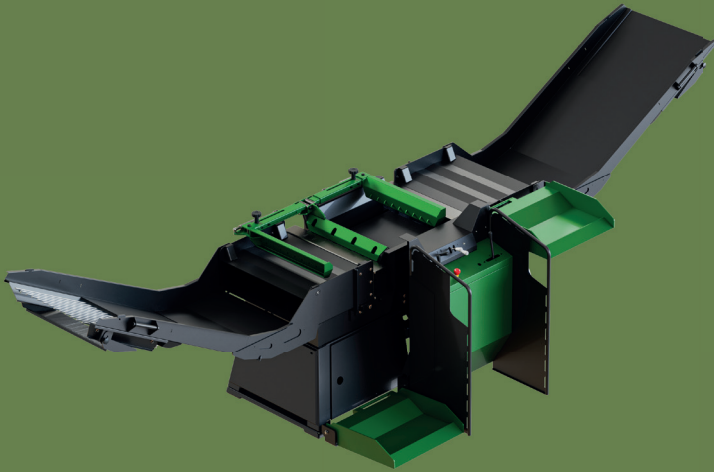

PRESERVE.

Discover the full power of nature with our forestry equipment. It's designed for the toughest challenges in the forest. Take control and set new standards. Don't follow - lead with our top-quality equipment built for durability and efficiency.



TECHNICAL DATA

RANGER E 250 E Horizontal log splitter

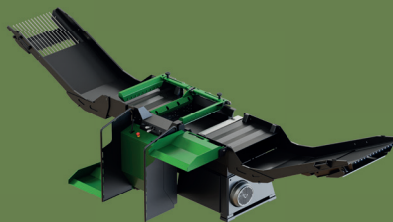

Drive		electric motor
Pump		Hi-Lo
Motor	kW	9,2 / 15
Splitting force	t	25
Splitting blade control		Ranger Velocity™*
Workpiece length	mm	250 - 570
Workpiece diameter (max.)	mm	600
Hydraulic oil capacity	l	74
Dimensions (H / W / L)	mm	1150 / 2010 / 1200
Work dimensions (H / W / L)	mm	1450 / 5300 / 1500
Weight	kg	1230
Usage purpose		Professional

**automatic speed adjustment*

**PERFORM. PROTECT.
PRESERVE.**

