

REDUCE.

# REUSER SD 600

## Universal shredder

REACT.

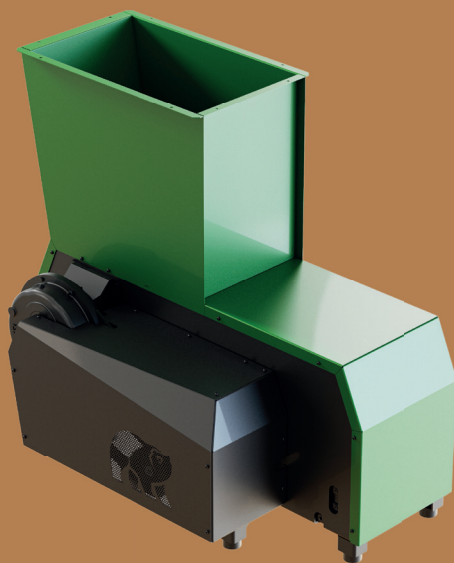

RECOVER.

Discover power and efficiency in a single step with our top-of-the-line shredders! With advanced technology and robust design, our shredders provide exceptional efficiency in processing a wide range of materials. Take control and set new standards. Don't follow - be a leader with our premium equipment, built for durability and efficiency.



# TECHNICAL DATA

## REUSER SD 600 universal shredder

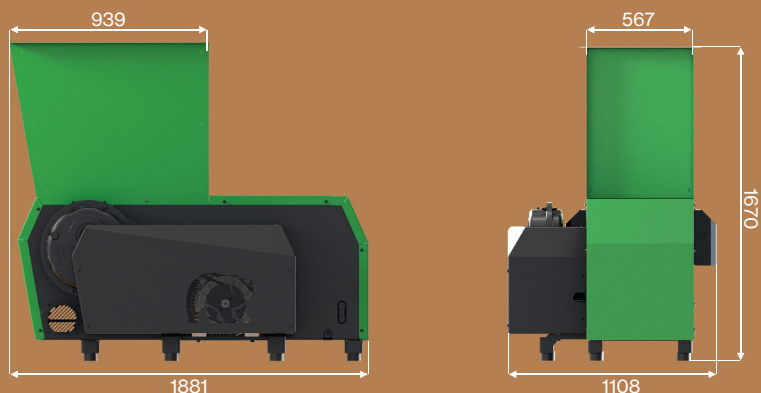

Rated capacity	kW	15 / 18,5
Cutting shaft	No.	1
Rotor length	mm	550
Number of blades	Pcs.	14
Rotor diameter	mm	260
Rotor speed	rpm	80 - 120
Hopper opening on the shaft	mm	810 x 549
Available screen sizes	mm	10/15/20/30
Hidraulic oil capacity	l	25
Dimensions (H / W / L)	mm	1670 / 1108 / 1881
Weight	kg	1250

**REACT. REDUCE.  
RECOVER.**

