

REDUCE.

# REUSER PD 1500

## Pre-shredder

REACT.

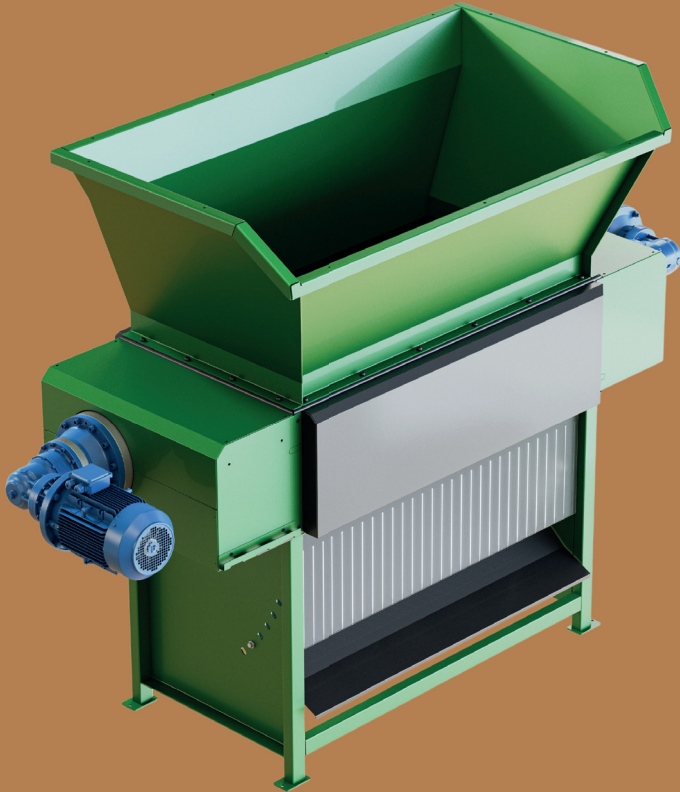

RECOVER.

Discover power and efficiency in a single step with our top-of-the-line shredders! With advanced technology and robust design, our shredders provide exceptional efficiency in processing a wide range of materials. Take control and set new standards. Don't follow - be a leader with our premium equipment, built for durability and efficiency.



# TECHNICAL DATA

## REUSER PD 1500 TWIN pre-shredder

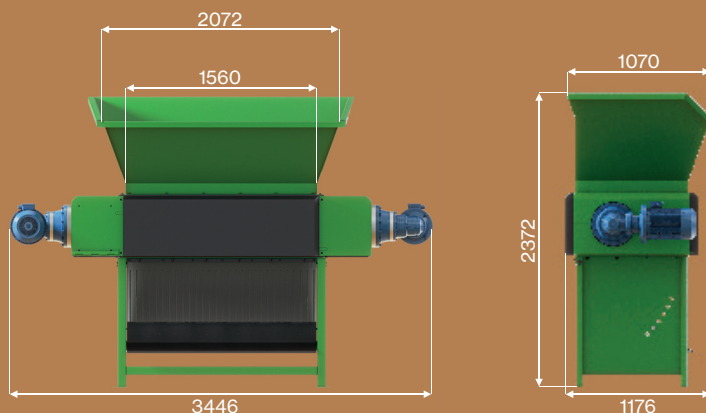

Rated capacity	kW	5,5 + 9,2
Cutting shaft	No.	2
Rotor length	mm	1580
Number of blades	Pcs.	2 x 12
Rotor diameter	mm	355
Rotor speed	rpm	5,3 + 10,3
Hopper opening on the shaft	mm	1560 x 800
Available screen sizes	mm	/
Hidraulic oil capacity	l	/
Dimensions (H / W / L)	mm	2372 / 3446 / 1176
Weight	kg	1840

**REACT. REDUCE.  
RECOVER.**

