

REDUCE.

REUSER HD 1500

Hybrid shredder

REACT.

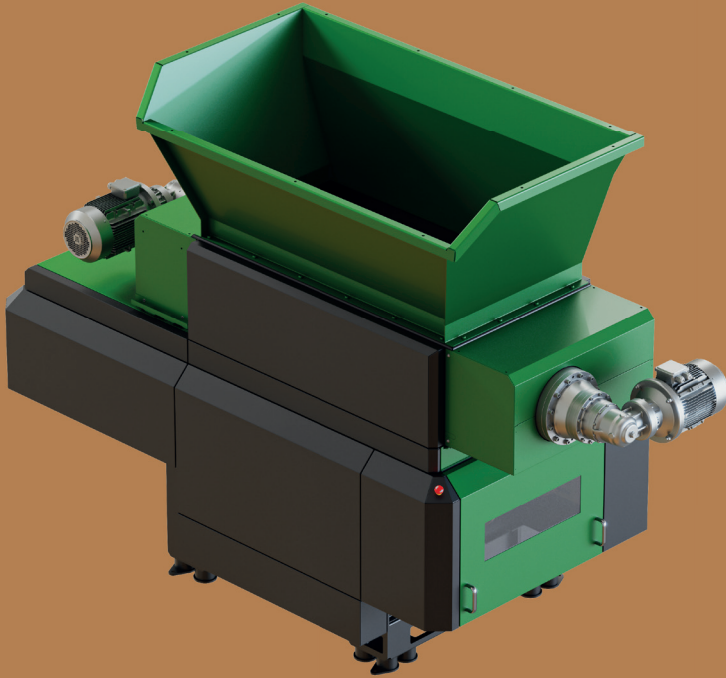

RECOVER.

Discover power and efficiency in a single step with our top-of-the-line shredders! With advanced technology and robust design, our shredders provide exceptional efficiency in processing a wide range of materials. Take control and set new standards. Don't follow - be a leader with our premium equipment, built for durability and efficiency.



TECHNICAL DATA

REUSER HD 1500 MONSTER hybrid shredder

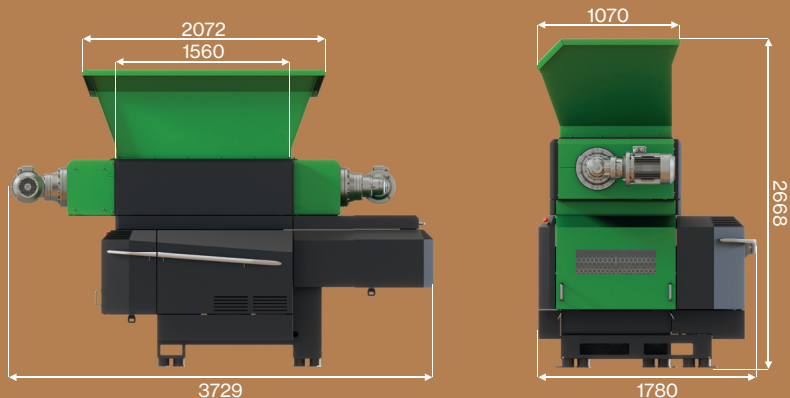

Rated capacity	kW	30 (shredder) + 5,5 and 9,2 (pre-shredder)
Cutting shaft	No.	1 (shredder) + 2 (pre-shredder)
Rotor length	mm	870 (shredder) + 1580 (pre-shredder)
Number of blades	Pcs.	38 (shredder) + 2 x 12 (pre-shredder)
Rotor diameter	mm	270 (shredder) + 355 (pre-shredder)
Rotor speed	rpm	80 - 120 (shredder) + 5,3 and 10,3 (pre-shredder)
Hopper opening on the shaft	mm	1560 x 800 (pre-shredder)
Available screen sizes	mm	10/15/16-12/20-15/30-20/30/40/50
Hidraulic oil capacity	l	30
Dimensions (H / W / L)	mm	2668 / 1780 / 3729
Weight	kg	4200

**REACT. REDUCE.
RECOVER.**

